

C O N T E N T S

1. SCOPE -----	3
2. RELATED DOCUMENTS -----	3
3. EXTERNAL REFERENCE SPEC. -----	3
4. REGULATORY INFORMATION -----	4
5. GENERAL CHARACTERISTICS -----	5
6. MECHANICAL CHARACTERISTICS -----	9
7. ELECTRICAL CHARACTERISTICS -----	10
8. ADJUSTMENTS -----	15
9. DISPLAY REQUIREMENTS -----	18
10. OPERATION OF CIRCUIT -----	25
11. PCB INFORMATION -----	28
12. RELIABILITY TEST SPEC. -----	30
13. PICTURES -----	31

1 . SCOPE

The monitor described in the followings is based on a 19" diagonal tri-color shadow mask CRT utilizing an in-line electron gun assembly.

This display device is composed of the CRT with deflection yoke, the small PCB containing the CRT socket and the large PCB containing the deflections, the micom circuits, the power supply and the video amplifier circuit.

This specification defines a high resolution 19" color monitor to be operated in analog drive mode input.

2 . RELATED DOCUMENTS

- 2.1 Parts list.
- 2.2 Service manual
- 2.3 Product outgoing inspection specification.
- 2.4 Schematic & waveform of circuit.
- 2.5 Touch Integration Manual.

3 . EXTERNAL REFERENCE SPEC .

Refer to 4 . REGULATORY INFORMATION .

4 . REGULATORY INFORMATION

4.1 SAFETY APPROVAL.

The system will be certified according to the following international safety standards.

- * UL : UL1950 (be in progress now)
- * CSA : CSA C22.2 N01 (be in progress now)
- * CE(LVD) : EN60065 (be in progress now)
- * TUV : EN60065 (be in progress now)
- * CB : IEC60950 (be in progress now)

4.2. ELECTROMAGNETIC INTERFERENCE.

The system will be certified according to the following international radiation standards.

- * CE(EMC) : EN55022:97 (be in progress now)
- * FCC : PART 15 CLASS A VERIFICATION (be in progress now)

4.3 X-RADIATION.

The X-radiation emitted from this picture tube will not exceed 0.5mR/h for anode current combination.

X-radiation at a constant anode voltage varies linearly with anode current.

4.3.1 The system will comply with the following international standards.

- * DHHS 21 CFR SUB CH J (be in progress now)

KORTEK CORP. (All Rights Reserved)

5 . GENERAL CHARACTERISTICS

5.1 OPERATION OF CONTROL PART.

5.1.1 Front panel

MENU(SELECT) : In the beginning, starts the OSD controls.
 In a sub menu, moves the control to the higher level.

EXIT : In the main menu, exits the OSD controls.

UP : In the beginning, proceeds to the contrast adjustment.
 In the main menu, moves the control menu to the right.
 In a sub menu, increase the adjustment.

DOWN : In the main menu, moves the control menu to the left.
 In a sub menu, decrease the adjustment.

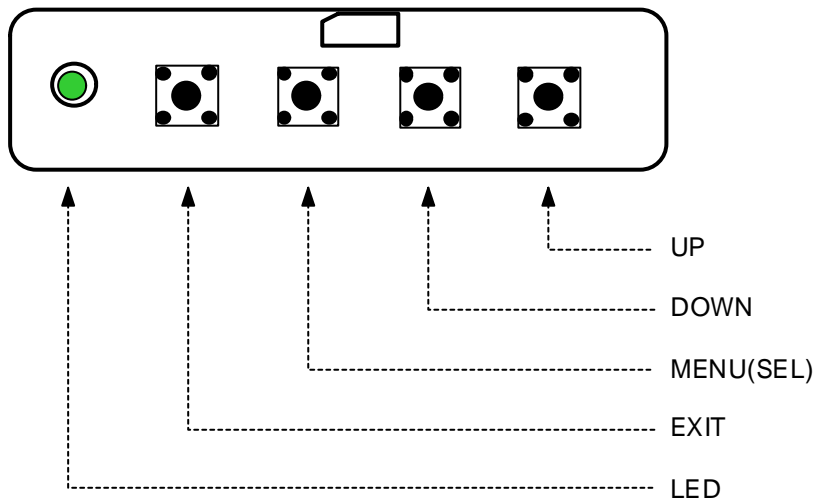

PRODUCT SPEC

5.3 CRT SPEC. & DIMENSION.

5.3.1 CRT DIMENSION.(samsung) : KT-1982F

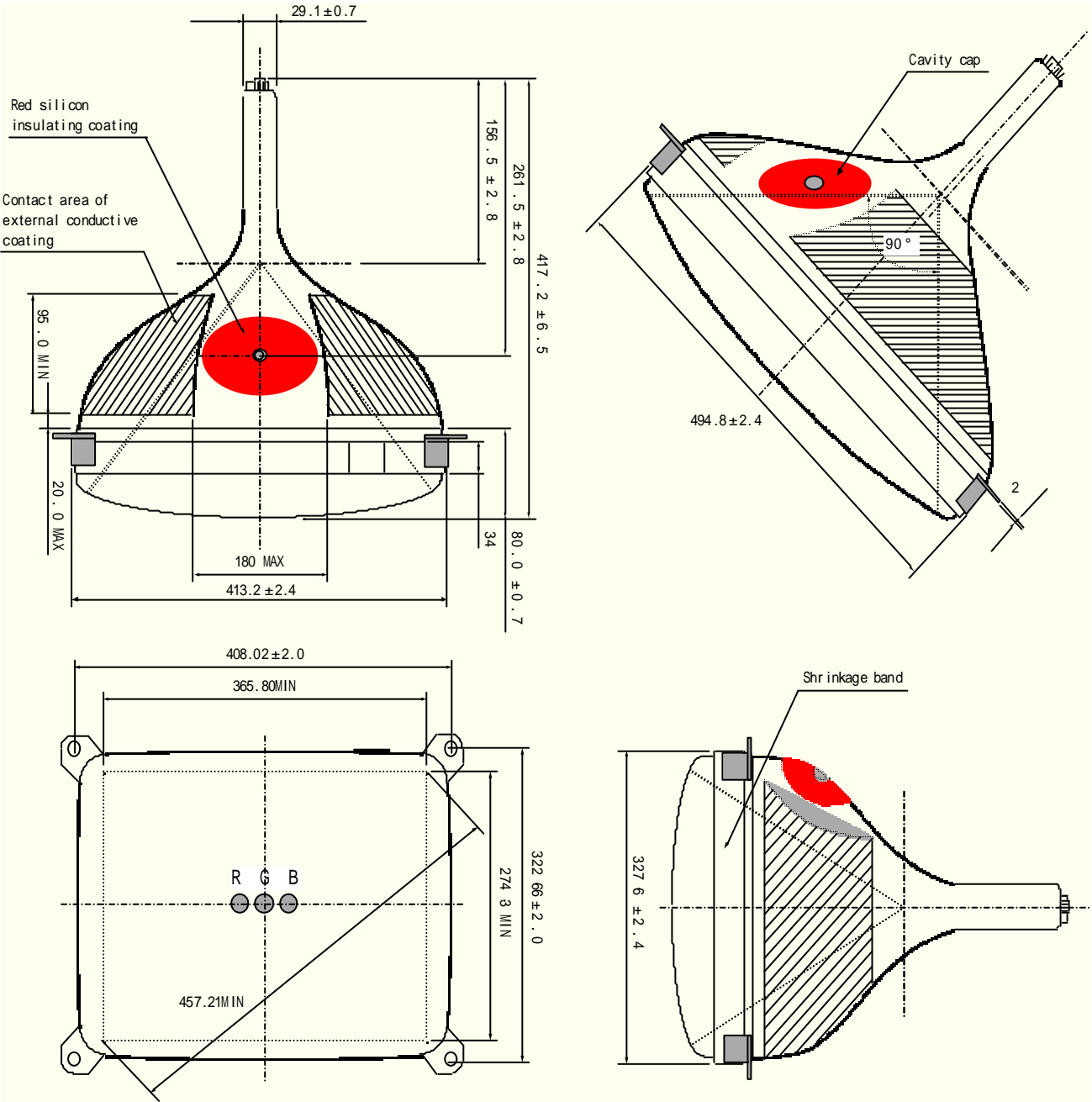

KORTEK CORP. (All Rights Reserved)

DOCUMENT NO : 1982 *****-MS

REV. NO : 1

Page 5 Of 26

5.3.2. CRT DIMENSION.(SAMSUNG DYNAFLAT): KT-1982D

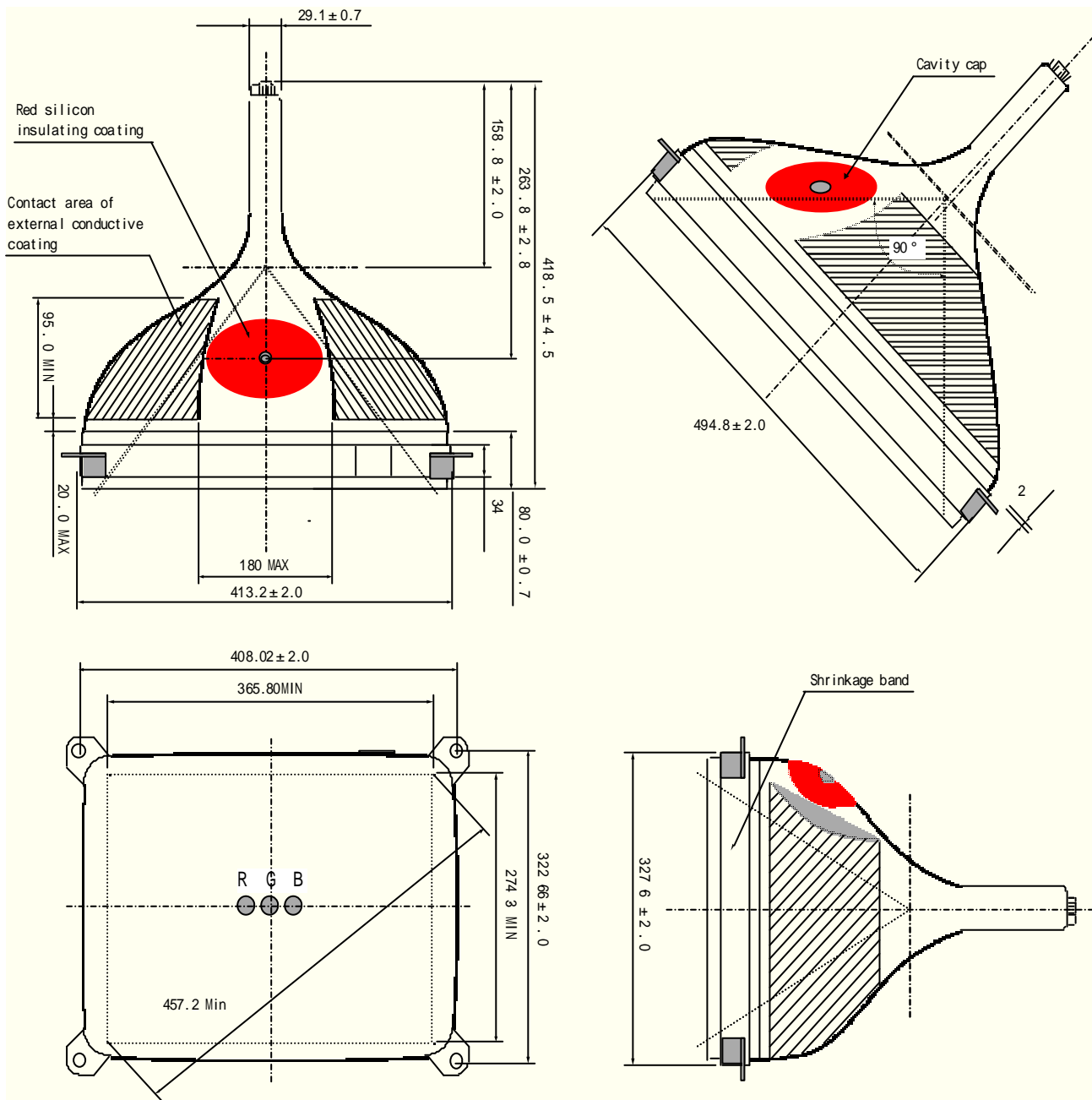

KORTEK CORP. (All Rights Reserved)

5.3.3. CRT DIMENSION.(SAMSUNG SHORT NECK): KT-1982S

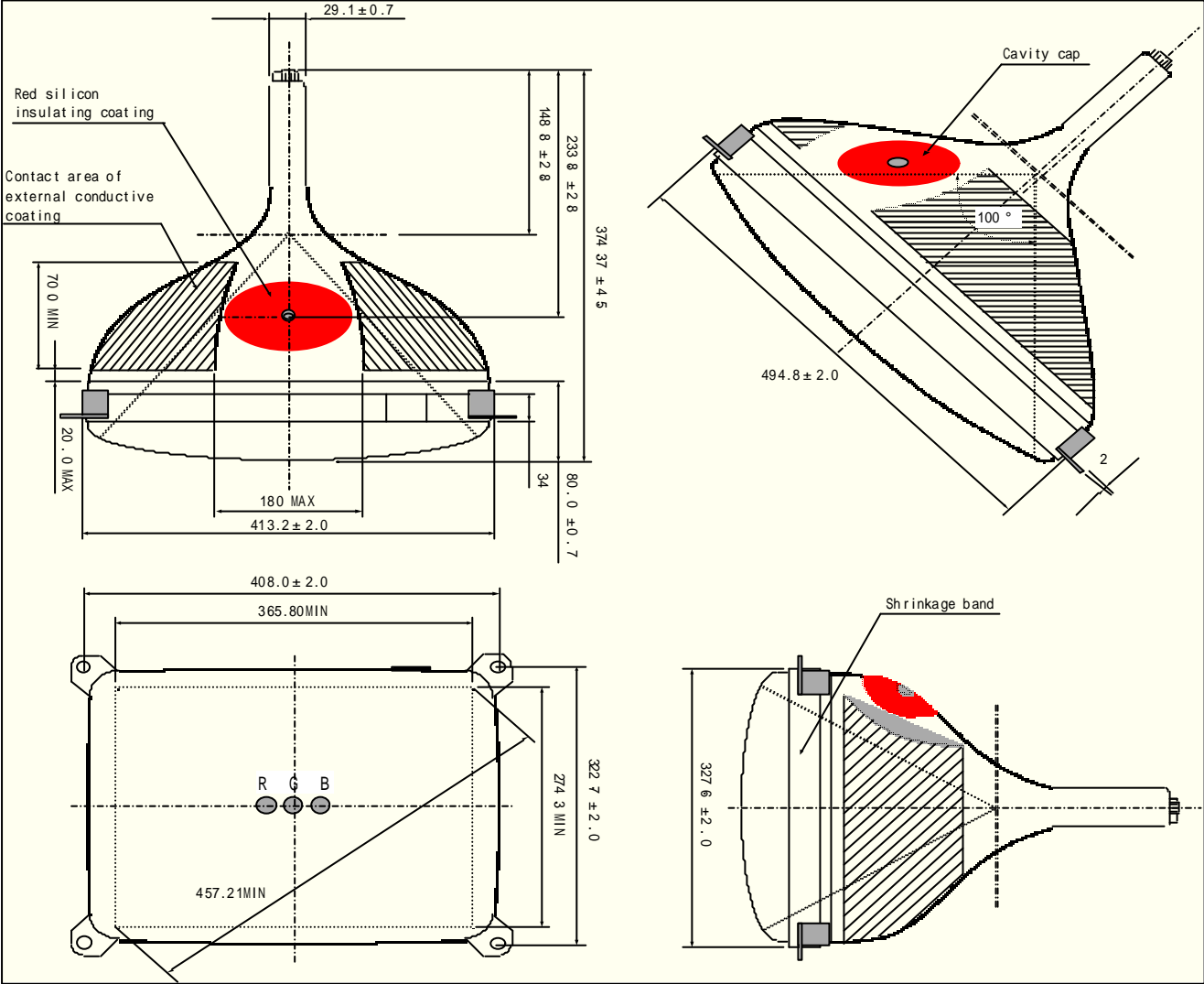

PRODUCT SPEC

5.4 SIGNAL CABLE & CONNECTION.

5.4.1 Signal cable

A shield signal interface cable must be intended as a part of the monitor.

The cable length shall be 1800 mm with a tolerance of $\pm 50\text{mm}$.

This cable shall be of a suitable type in order to comply with any specification item, and shall be terminated in a 15 pin D-shell male connector type FOXCONN D973292-8 or equivalent, with pin assignment as follows.

5.4.2 SIGNAL CABLE PIN CONNECTION (15 PIN D-SUB MINIATURE SIGNAL CONNECTOR WITH CABLE)

CONNECTION				REMARK
D-SUB 15PIN	IBM PC	WIRE COLOR	6P CONN 6P CONN	
1	RED	RED COAX-IN	6P CONN-1	
2	GREEN	GREEN COAX-IN	6P CONN-3	
3	BLUE	BLUE COAX-IN	6P CONN-5	
4	N.C	-	-	
5	GND	BLACK COAX-GND		
6	RED-GND	RED COAX-GND	6P CONN-2	
7	GREEN-GND	GREEN COAX-GND	6P CONN-4	
8	BLUE-GND	BLUE COAX-GND	6P CONN-6	
9	N.C	-	-	
10	ID	GRAY	6P CONN-3	
11	N.C	-	-	
12	SDA	YELLOW	6P CONN-5	
13	H-SYNC	ORANGE	6P CONN-1	
14	V-SYNC	WHITE	6P CONN-2	
15	SCL	RED	6P CONN-4	
SHELL	GND	BLACK	6P CONN-6	

5.4.3 BUYER CONNECTOR PIN CONNECTION (OPTION)

KORTEK CORP. (All Rights Reserved)

PRODUCT SPEC

6 . MECHANICAL CHARACTERISTICS .

6.1 PRODUCT DIMENSION.(unit : mm)

Description	With stand	Packaging
Width	430	500
Height	405	550
Length	490	460

6.2 WEIGHT : NET kg
 GROSS kg

6.3 MECHANICAL MATERIALS.

6.3.1 INTERNAL METAL PARTS.

* PCB GUIDE CHASSIS DIMENSION

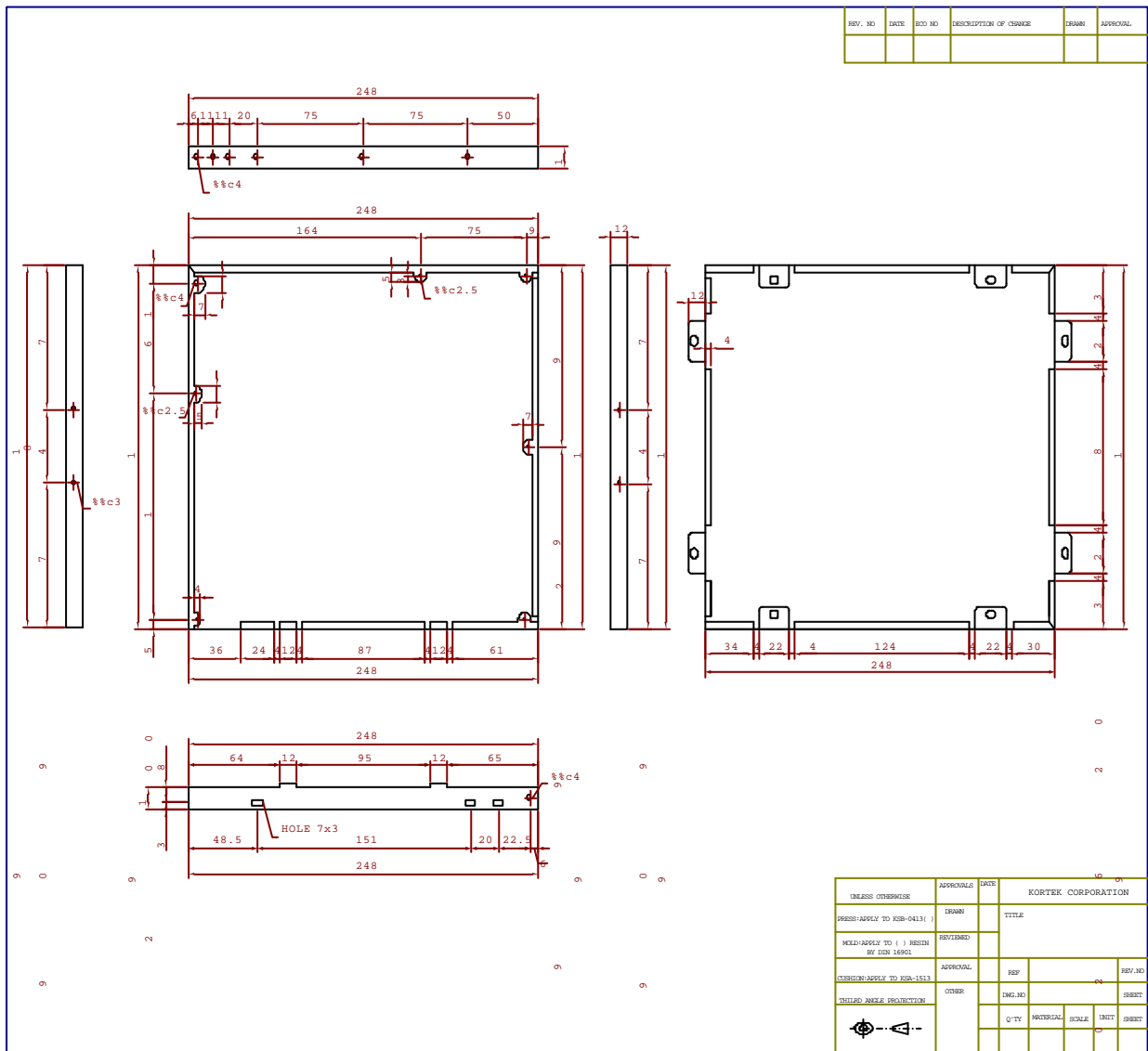

KORTEK CORP. (All Rights Reserved)

DOCUMENT NO : 1982 *****-MS

REV. NO : 1

Page 9 Of 26

PRODUCT SPEC

6.3.1 FRAME METAL PARTS. (BUYER OPTION) FRONT (STANDARD FRAME)

* MAIN FRAME CHASSIS (STANDARD)

REV. NO	DATE	ECO NO	DESCRIPTION OF CHANGE	DRAWN	APPROVAL

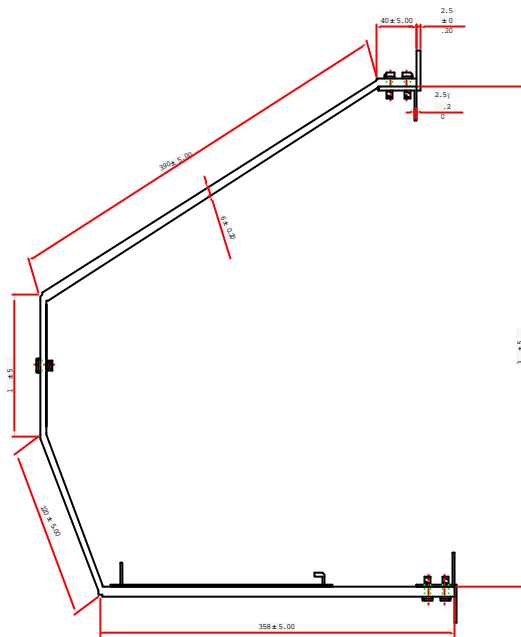
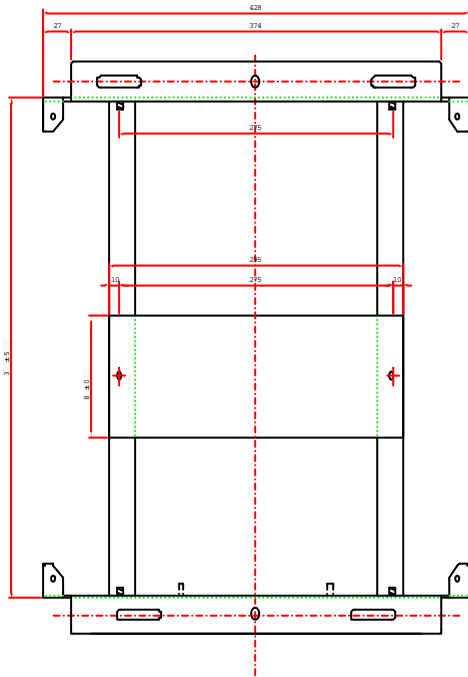

UNLESS OTHERWISE	APPROVALS	DATE	KORTEK CORPORATION			
PRESS-APPLY TO KSB-0413()	DESIGN		TITLE			
MOLD-APPLY TO () RESIN BY DIN 16901	REVISED					
	APPROVAL		REP		REV. NO	

KTA-0503-00-01

()

KORTEK CORP. (All Rights Reserved)

DOCUMENT NO : 1982 *****-MS

REV. NO : 1

Page 10 Of 26

PRODUCT SPEC

7. ELECTRICAL CHARACTERISTICS.

7.1 BLOCK DIAGRAM

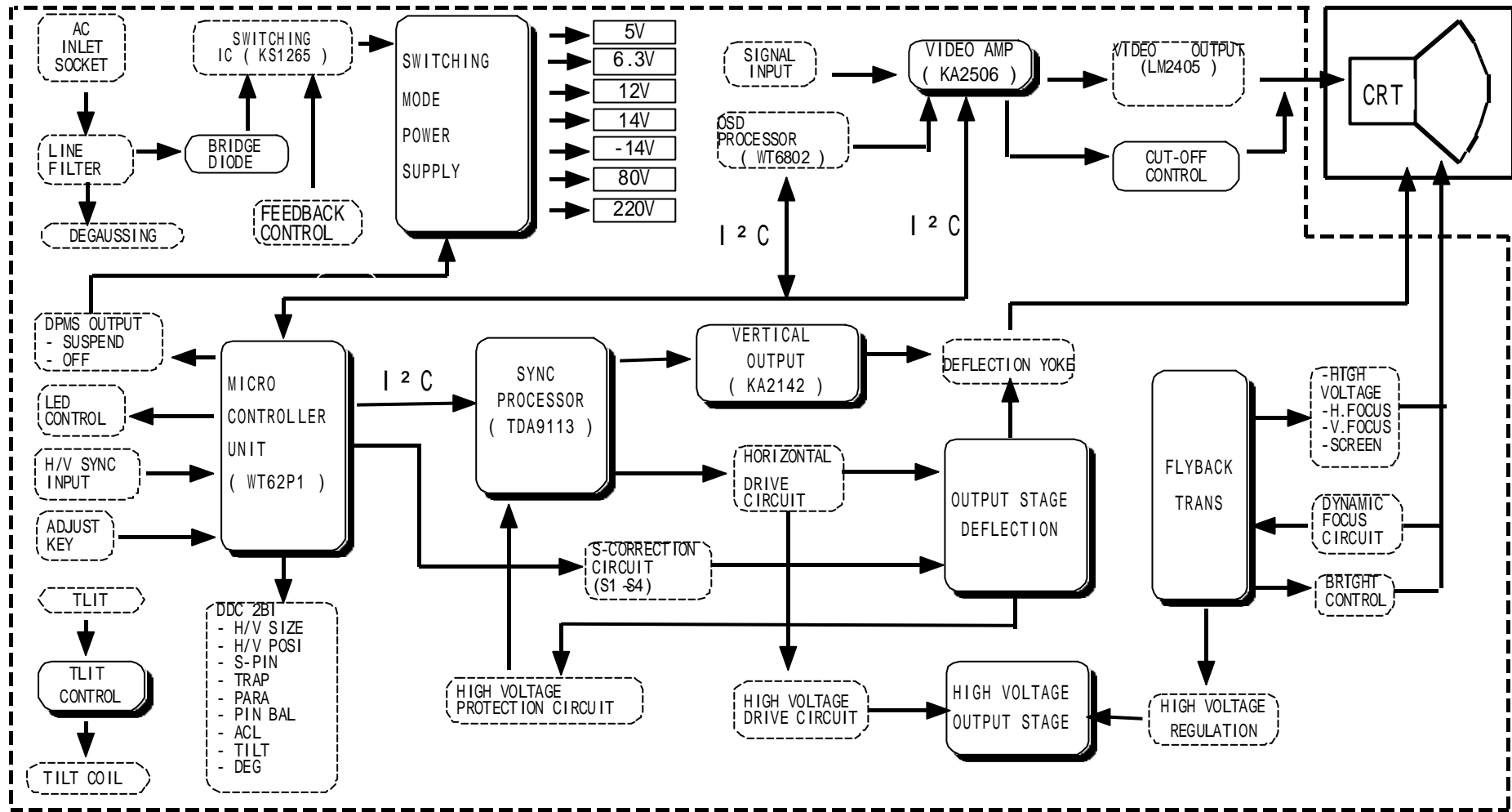

KORTEK CORP.. (All Rights Reserved)

PRODUCT SPEC

7.2 INPUT POWER.

The display device shall maintain the specified performances in the range described below.

NO	DESCRIPTION	NOMINAL	REMARKS
1	Power Source	AC 90V ~ 264V	Universal Power
2	Frequency	47.5 ~ 63Hz	
3	Power Consumption	MAX. 100W	

7.3 SIGNAL & SYNS.TIMING

The input signals shall be applied to the display device through the signal cable which must be intended as part of the monitor.

SECTION	DESCRIPTION	NOMINAL	REMARKS
VIDEO SIGNAL RED GREEN BLUE	VIDEO INPUT	0.0 to 0.714Vp-p ANALOG	
	POLARITY	POSITIVE	
	PIXEL RATE	MAX. 120MHz	
	MAX. RESOLUTION	1024 × 768 / 100Hz	
	INPUT IMPEDANCE	75 ohms	
SYNC SIGNAL	TYPE	SEPARATE H/V COMPOSITE H/V	
	POLARITY	POSITIVE OR NEGATIVE	
	FREQUENCY	HOR.: 30 81KHz VER.: 50 160 Hz	
	LEVEL	SEPARATE SYNC : HIGH 2.0V, LOW 0.8V	

KORTEK CORP. (All Rights Reserved)

DOCUMENT NO : 1982 *****-MS

REV. NO : 1

Page 12 Of 26

PRODUCT SPEC

7.4 TIMING CHART (FACTORY MODE)

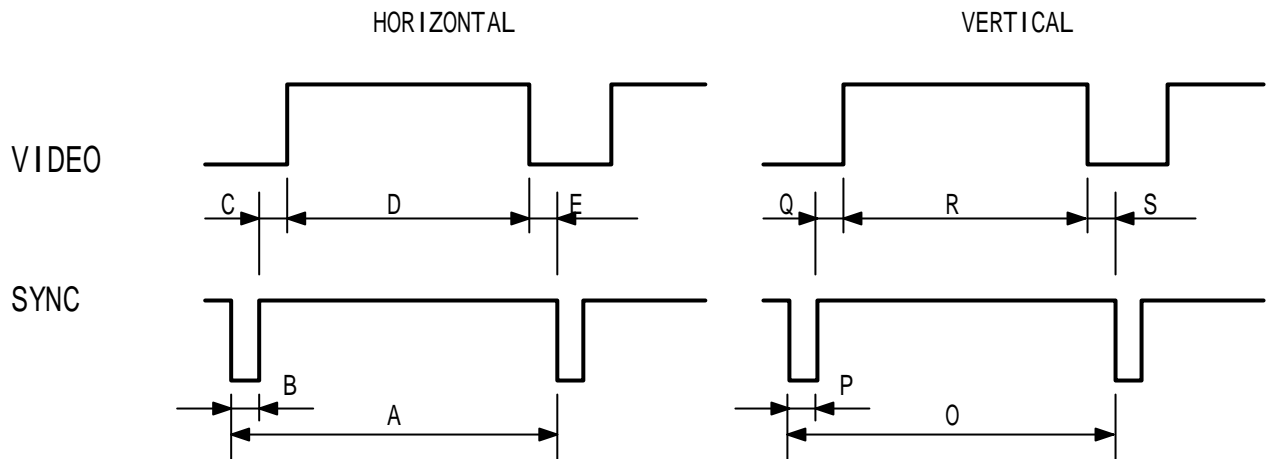

DESCRIPTION	I.B.M			VESA												
	720*400	640*480	1024*768 (1)	640*480	800*600	800*600	800*600	800*600	1024*768	800*600	1024*768	1024*768	1280*1024	1024*768	1280*1024	1024*768
H	f KHz	31.469	31.469	35.52	37.860	37.88	46.875	48.077	48.363	53.674	56.476	60.241	63.702	68.677	79.976	81.400
	A uS	31.778	31.778	28.15	26.413	26.40	21.333	20.800	20.677	18.631	17.707		15.698	14.561	12.504	12.285
	B uS	3.813	3.813	3.92	1.270	3.20	1.616	2.400	2.092	1.138	1.813		1.358	1.016	1.067	0.988
	C uS	1.907	1.907	1.25	4.603	2.20	3.232	1.280	2.262	2.702	1.920		1.812	2.201	1.837	1.624
	D uS	25.422	25.422	22.80	20.317	20.00	16.162	16.000	15.754	14.222	13.653		12.075	10.836	9.481	9.037
	E uS	0.636	0.636	0.18	0.762	1.00	0.323	1.120	0.369	0.569	0.320		0.453	0.508	0.119	0.635
	POL.	NEG	NEG	POS	POS	POS	POS	POS	NEG	POS	NEG		NEG	POS	NEG	POS
V	f Hz	70.087	59.940	86.906	72.809	60.317	75Hz	72.188	60.00	85.061	70.00	75Hz	60.00	84.997	75.025	100.00
	O mS	14.268	16.683	11.50	13.735	16.58	13.333	13.853	16.667	11.756	14.272		16.640	11.765	13.329	10.000
	P mS	0.064	0.064	0.113	0.079	0.11	0.064	0.125	0.124	0.056	0.106		0.047	0.044	0.038	0.037
	Q mS	1.080	1.048	0.563	0.740	0.61	0.448	0.478	0.60	0.503	0.513		0.471	0.524	0.475	0.516
	R mS	12.711	15.253	10.81	12.678	15.84	12.8	12.480	15.88	11.179	13.599		16.075	11.183	12.804	9.435
	S mS	0.413	0.318	0.014	0.238	0.03	0.021	0.770	0.062	0.019	0.053		0.047	0.015	0.013	0.012
	POL.	POS	NEG	POS	POS	POS	POS	POS	NEG	POS	NEG		NEG	POS	POS	POS

KORTEK CORP. (All Rights Reserved)

8 . A D J U S T M E N T S

8.1 DEFLECTION CIRCUIT ADJUSTMENT

8.1.1 Screen position adjustment. (H-SHIFT,V-SHIFT)

* Receive a cross-hatch pattern signal of all factory preset mode.

* Adjust H-SHIFT,V-SHIFT for the screen position to center.

NOTE : All of the user control functions are adjustable when the OSD appears on the screen.

8.1.2 Horizontal size adjustment. (H-SIZE)

* Adjust contrast and brightness controls to maximum.

* Receive a cross-hatch pattern signal of all modes.

* Adjust H-SIZE for the horizontal size equal to 400 ± 3.0 mm.

8.1.3 Vertical size adjustment. (V-SIZE)

* Adjust contrast and brightness controls to maximum .

* Receive a cross-hatch pattern signal of all modes.

* Adjust V-SIZE for the vertical size equal to 295 ± 3.0 mm.

8.1.4 Pincushion adjustment. (Pincushion)

* Receive a cross-hatch pattern signal of all modes.

* Adjust Pincushion for compensation of the east/west distortion.

8.1.5 Trapezoidal adjustment

* Receive a cross-hatch pattern signal of all modes.

* Adjust TRAPEZOIDAL for compensation of the geometric distortion..

8.1.6 Parallelogram adjustment

* Receive a cross-hatch pattern signal of all modes.

* Adjust PARALLELOGRAM for compensation of the geometric distortion.

8.1.7 Pin Balance adjustment

*Receive a cross-hatch pattern signal of all modes.

*Adjust PIN BALANCE for compensation of the geometric distortion.

8.1.8 Tilt(Rotation) Adjustment

*Receive a cross-hatch pattern signal of all modes

*Adjust tilt(Rotation) for compensation of the geometric distortion.

8.2 VIDEO CIRCUIT ADJUSTMENT.

8.2.1 Control function.

* Contrast control

This function controls the contrast of the screen, and determines the gain of the video amplifier.

* R,G,B-GAIN controls.

These controls are used for adjusting the gain of RED, GREEN, BLUE video signals.

* R,G,B-BIAS controls.

These controls are used for adjusting the RED, GREEN, BLUE bias-voltage of Cathode.

* Focus control. (On the FBT)

This controls determines the optimum focus of the screen.

8.3 THE ADJUSTMENT OF WHITE BALANCE.

* Adjust the screen V/R control slowly so that voltage of G2 is equal to 580 ~ 600 volt.

* Operate the monitor for 15 minutes in order to warm up the CRT and circuits.

* Degauss the CRT face fully with degaussing tool.

* Adjust brightness and contrast to the 80% value.

* Receive a raster pattern of 800*600 48KHz, 60Hz mode.

* Adjust R,G,B-BIAS controls so that the raster becomes white and luminance is 0.5(F/L) and for the specified color coordinate.

* Receive a one ball white pattern of 800*600 48KHz, 60Hz mode.

* Adjust R,G,B-GAIN controls for the specified white color with the color analyzer.

* Receive a full white screen of 800*600 48KHz, 60Hz mode.

* Adjust ACL controls for the specified luminance with the color analyzer.

SPECIFICATIONS.

Standard color coordinate.(BRT,CONT; 80%) * 6500 ° K ; X=0.313 ± 0.02 Y=0.329 ± 0.02 * 9300 ° K ; X=0.281 ± 0.02 Y=0.311 ± 0.02 Maximum brightness : BRT,CONT ;80% - With full white pattern ; 25 30 F/L (9300&6500。 K) BUYER OPTION - With one ball white pattern ; 50 60 F/L (9300&6500。 K) BUYER OPTION - Checking area : Center of display.

9. DISPLAY REQUIREMENTS

9.1 Engineering check and test equipment

9.1.1 Engineering check

This specification defines a high resolution 19" color monitor to be operated in analog drive mode.

This procedure defines test & inspection requirements, and acceptance criteria for visual and functional characteristics.

9.1.2 Test equipment.

1. Personal computer or signal generator, test program(software) for color monitor.
2. Color-Analyzer (CA-100).
3. Display template for screen adjustment.

9.2 Engineering check point.

9.2.1 Packaging.

Check the packaging to make sure the unit is in a shippable condition.

The following items shall be verified.

- * BOX.
- * LABEL

9.2.2 Enclosure

The monitor, intended as a finished product, shall comply with any ergonomic and safety specification contained in box.

PRODUCT SPEC

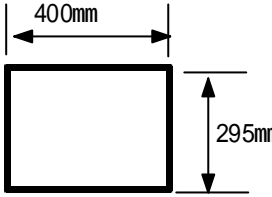
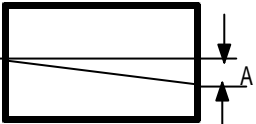
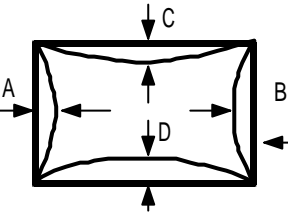
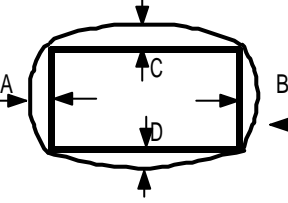
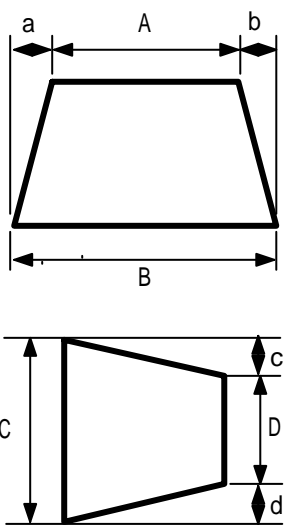
NO	ITEM	SPECIFICATION	REQUIREMENT	Pattern
1	VISUAL		Standard direction : N/E (all items)	
1-1	DISPLAY SIZE (Standard)		A.Display the cross hatch pattern. B.The size must be adjustable to the followings by using user's control for all specified mode. * Horizontal size : 400±3mm. * Vertical size : 295±3mm .	Cross-hatch (640/60Hz)
1-2	LINEARITY	Linearity $\frac{L_{max}-L_{min}}{L_{max}+L_{min}} \times 100\%$	A.The linearity of screen must be displayed on the CRT within the spec.(Horizontal and vertical) * Ver : 5% Hor : 5%	16 × 12 square pattern (640/60Hz)
1-3	TILT		A.The tilt must be within the limit of the spec. * A = ± 1.3mm MAX.	Cross-hatch pattern (640/60Hz)
1-4	1) PINCUSHION		* Maximum allowable error; A,B : Lessthan 2.0 mm C,D : Lessthan 2.0 mm	"
	2) BARREL		* Maximum allowable error; A,B : Lessthan 1.0 mm C,D : Lessthan 1.5 mm	"
	3) TRAPEZOID		* A-B 2.0 mm * C-D 2.5 mm * a, b, c, d 2.5 mm	"

KORTEK CORPORATION. (All Rights Reserved)

PRODUCT SPEC

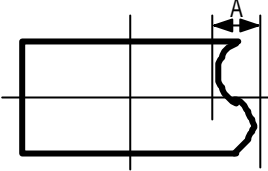
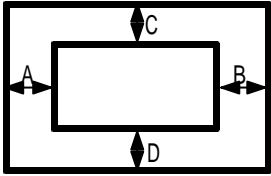
NO	ITEM	SPECIFICATION	REQUIREMENT	Pattern
1-4	4) PARALLELOGRAM		* A, B 2.0 mm	Cross-hatch (640/60Hz)
	5) "S" CURVE		* A 2.0 mm	"
1-5	DISPLAY-CENTER		* A-B 6 mm * C-D 4 mm * The maximum variation of the display center have to be within the spec.	"
1-6	FOCUS	* Visual test	* Cut off the back raster. (0.07F/L) * Adjust contrast maximum or 47F/L at one ball white pattern. * Change pattern to "windows-me pattern". * Check the focus of the dots, bars, and characters.	Windows-me pattern (640/60Hz)
1-7	JITTERING	* Visual test	* There shall be no jitter when the screen is viewed from 45 Cm	"
1-8	MIS CONVER-GENCE	* A zone(295mm circle):0.25mm MAX * B zone :0.35 mm max.	* Measure the distance between red, green and blue lines with a microscope after the proper adjustment of white balance.	Cross-hatch
1-9	ACOUSTIC NOISE	* Not any audible sound	* During the display operating, it has not to be any audible sound.	"
1-10	WHITE BALANCE	* 6500 _o K X=0.313 ± 0.02 Y=0.329 ± 0.02 * 9300 _o K X=0.281 ± 0.02 Y=0.311 ± 0.02	* The white color coordinates in the center of the surface of CRT after proper adjustment of white balance * Cont; 80% (DEFAULT VALUE)	Full white pattern (0.7V Level)
1-11	WHITE COLOR TRACKING	* 6500 _o K X = 0.313±0.02 Y = 0.329±0.02 * 9300 _o K X = 0.281±0.02 Y = 0.311±0.02 * 10 F/L and MAX	* Set contrast control at 10 and MAX * Measure it in the center of CRT. * No one color shall achieve dominance, when the standard white color is displayed at all the allowed settings of the contrast control.	"
1-12	PURITY	* Visual test	* After degaussing, it has not to be any perceptible color shift in the scanning area while viewing a primary color field at 30 cm's distance.	R,G,B Primary color pattern
1-13	RASTER REGULATION	* Less than 1.5 mm at one side	* Measure it from minimum to maximum luminance at full white screen.	Full white pattern (640/60Hz)

KORTEK CORP. (All Rights Reserved)

DOCUMENT NO : 1982 *****-MS

REV. NO : 1

Page 18 Of 26

PRODUCT SPEC

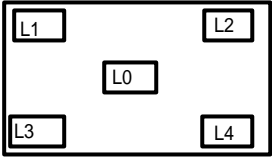
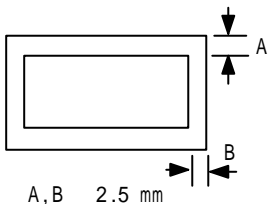
NO	ITEM	SPECIFICATION	REQUIREMENT	Pattern
1-14	BRIGHTNESS UNIFORMITY	* More than 75%	* Measure it at center contrast to 25 F/L, BRT : cut-off	Full white pattern
1-15	WHITE UNIFORMITY		* BRT ; max * CONT ; max. * COLOR MODE ; 9300, K * The X or Y coordinate between any position in the entire display area shall not vary more than 0.015 * X of L1,L2,L3,L4 X of L0±0.015 * Y of L1,L2,L3,L4 Y of L0±0.015	"
1-16	MOIRE	* Visual test	* No any visible moire at 20F/L, "A"Zone (230mm circle) * Full white pattern (1024 x 768/60Hz)	Full white pattern
1-17	MODE CHANGE	* Visual test	* Upon changing modes, the display image must be stable and meet all image performance specifications within 1.0 second. * Mute time must be longer than the input signal recognition time.	all modes
1-18	LUMINANCE	* FULL WHITE PATTERN : 25 27 F/L * ONE BALL WHITE : 45 65 F/L * MINIMUM LUMINANCE : LESS THAN 3F/L	* CONTRAST : MAX * 9300, K, 6500, K * MINIMUM LUMINANCE : CONTRAST : MIN. * BRIGHTNESS : MIN.	Full white pattern (1024 X768/60Hz)
1-19	GRAY SCALE LINEARITY	* VISUAL TEST	*CONTRAST : MAX. ;The 16 step gray bars shall be distinguishable. *CONTRAST : MAX. ;More than 15 step gray bars are distinguishable.	16 gray pattern (1024 x768/60Hz)
1-20	RASTER LUMINANCE	* 0.5 F/L (BUYER OPTION)	* CONTRAST ; MAX. * 6500 ° K; X=0.313 ± 0.02 Y=0.329 ± 0.02 * 9300 ° K; X=0.281 ± 0.02 Y=0.311 ± 0.02	1024 x768/60Hz
1-21	DYNAMIC REGULATION	* LESS THAN 1.0mm ONE SIDE	*CONTRAST:MAX. *USE HORIZONTAL BAR PATTERN	1024 x768/60Hz
1-22	SIZE CONTROL RANGE	* HORIZONTAL : LESS THAN 310mm, MORE THAN OVER SCAN * VERTICAL : LESS THAN 215mm, MORE THAN OVER SCAN		CROSS-HATCH (1024/60Hz)
1-23	TOTAL DISTORTION		* In case of factory preset mode, the image performance meets specification without user adjustments. * In case of user mode, the image performance meets the specifications with user adjustments.	CROSS-HATCH (1024X768/60Hz)
1-24	BENT ON TOP	LESS THAN 0.5mm		CROSS-HATCH (1024/60Hz)
1-25	SPOT	VISUAL TEST	*No any visible spot at power-off *No any visible spot at mode change	"
1-26	RINGING	VISUAL TEST	*Ringing, vertical black bar shall not be visible to the eye when viewed at 50cm from CRT surface and video is positioned center.	FULL WHITE (1024/60Hz)
1-27	OSD Color&Position	VISUAL TEST	*No discolor *In case of factory preset mode, OSD display is located at just center position.	All modes
1-28	OSD NOISE&distorion	VISUAL TEST	*No visible OSD distortion &Noise	All modes

KORTEK CORP. (All Rights Reserved)

PRODUCT SPEC

9.2.4 CRT SPECIFICATIONS

NO	ITEM	SPECIFICATION	RMK.																																																									
1.	HIGH CONTRAST BLEMISHES	<table border="1"> <thead> <tr> <th rowspan="2">BLEMISH</th> <th colspan="3">ALLOWABLE NUMBER OF BLEMISH</th> <th colspan="3">ALLOWABLE MINIMUM SEPARATION</th> </tr> <tr> <th>ZONE A</th> <th>ZONE B</th> <th>TOTAL</th> <th>ZONE A</th> <th>ZONE B</th> <th>ZONE A+B</th> </tr> </thead> <tbody> <tr> <td>1TRIO</td> <td>1</td> <td>1</td> <td>1</td> <td>--</td> <td>--</td> <td>50</td> </tr> <tr> <td>A</td> <td>0</td> <td>2</td> <td>2</td> <td>--</td> <td>50</td> <td>--</td> </tr> <tr> <td>B</td> <td>1</td> <td>2</td> <td>2</td> <td>--</td> <td>50</td> <td>50</td> </tr> <tr> <td rowspan="2">1DOT</td> <td>G</td> <td>3</td> <td>3</td> <td rowspan="2">5</td> <td rowspan="2">8</td> <td>--</td> <td>--</td> <td>--</td> </tr> <tr> <td>R,B</td> <td>5</td> <td>5</td> <td>8</td> <td>--</td> <td>--</td> <td>--</td> </tr> <tr> <td>LESS THAN</td> <td colspan="3">IGNORE</td> <td colspan="3">-----</td> </tr> </tbody> </table> <p>(A) 2 CONSECUTIVE SAME COLOR PHOSPHOR DOTS (B) 2 CONSECUTIVE DIFFERENT COLOR PHOSOPHOR DOTS *ZONE A : DISPLAY AREA (400 mm X 295 mm) *ZONE B : OTHER AREA</p>	BLEMISH	ALLOWABLE NUMBER OF BLEMISH			ALLOWABLE MINIMUM SEPARATION			ZONE A	ZONE B	TOTAL	ZONE A	ZONE B	ZONE A+B	1TRIO	1	1	1	--	--	50	A	0	2	2	--	50	--	B	1	2	2	--	50	50	1DOT	G	3	3	5	8	--	--	--	R,B	5	5	8	--	--	--	LESS THAN	IGNORE			-----			
BLEMISH	ALLOWABLE NUMBER OF BLEMISH			ALLOWABLE MINIMUM SEPARATION																																																								
	ZONE A	ZONE B	TOTAL	ZONE A	ZONE B	ZONE A+B																																																						
1TRIO	1	1	1	--	--	50																																																						
A	0	2	2	--	50	--																																																						
B	1	2	2	--	50	50																																																						
1DOT	G	3	3	5	8	--	--	--																																																				
	R,B	5	5			8	--	--	--																																																			
LESS THAN	IGNORE			-----																																																								
2.	MEDIUM CONTRAST BLEMISHES	<table border="1"> <thead> <tr> <th rowspan="2">BLEMISH</th> <th colspan="3">ALLOWABLE NUMBER OF BLEMISH</th> <th colspan="3">ALLOWABLE MINIMUM SEPARATION</th> </tr> <tr> <th>ZONE A</th> <th>ZONE B</th> <th>TOTAL</th> <th>ZONE A</th> <th>ZONE B</th> <th>ZONE A+B</th> </tr> </thead> <tbody> <tr> <td>3 CONSECUTIVE DOTS</td> <td>1</td> <td>2</td> <td>2</td> <td>--</td> <td>30</td> <td>30</td> </tr> <tr> <td>2 CONSECUTIVE DOTS</td> <td>2</td> <td>5</td> <td>5</td> <td>30</td> <td>20</td> <td>20</td> </tr> <tr> <td>1 DOT</td> <td>IGNORE</td> <td>IGNORE</td> <td>IGNORE</td> <td>--</td> <td>--</td> <td>--</td> </tr> </tbody> </table> <p>*MINIMUM SEPARATION IS 20mm AMONG HIGH AND MEDIUM CONTRAST BLEMISHES. (EXCLUDING 1 DOT MEDIUM CONTRAST BLEMISHES)</p>	BLEMISH	ALLOWABLE NUMBER OF BLEMISH			ALLOWABLE MINIMUM SEPARATION			ZONE A	ZONE B	TOTAL	ZONE A	ZONE B	ZONE A+B	3 CONSECUTIVE DOTS	1	2	2	--	30	30	2 CONSECUTIVE DOTS	2	5	5	30	20	20	1 DOT	IGNORE	IGNORE	IGNORE	--	--	--																								
BLEMISH	ALLOWABLE NUMBER OF BLEMISH			ALLOWABLE MINIMUM SEPARATION																																																								
	ZONE A	ZONE B	TOTAL	ZONE A	ZONE B	ZONE A+B																																																						
3 CONSECUTIVE DOTS	1	2	2	--	30	30																																																						
2 CONSECUTIVE DOTS	2	5	5	30	20	20																																																						
1 DOT	IGNORE	IGNORE	IGNORE	--	--	--																																																						
3.	LOW CONTRAST BLEMISHES	<table border="1"> <tbody> <tr> <td>BLEMISHES IN ZONE A</td> <td>EQUIVALENT DIAMETER OF THE TOTAL AREA OF LOW-CONTRAST BLEMISHES SHOULD BE LESS THAN 13 mm.</td> </tr> <tr> <td>BLEMISHES IN ZONE B</td> <td>EQUIVALENT DIAMETER OF THE TOTAL AREA OF LOW-CONTRAST BLEMISHES SHOULD BE LESS THAN 50 mm.</td> </tr> </tbody> </table>	BLEMISHES IN ZONE A	EQUIVALENT DIAMETER OF THE TOTAL AREA OF LOW-CONTRAST BLEMISHES SHOULD BE LESS THAN 13 mm.	BLEMISHES IN ZONE B	EQUIVALENT DIAMETER OF THE TOTAL AREA OF LOW-CONTRAST BLEMISHES SHOULD BE LESS THAN 50 mm.																																																						
BLEMISHES IN ZONE A	EQUIVALENT DIAMETER OF THE TOTAL AREA OF LOW-CONTRAST BLEMISHES SHOULD BE LESS THAN 13 mm.																																																											
BLEMISHES IN ZONE B	EQUIVALENT DIAMETER OF THE TOTAL AREA OF LOW-CONTRAST BLEMISHES SHOULD BE LESS THAN 50 mm.																																																											

KORTEK CORP. (All Rights Reserved)

PRODUCT SPEC

NO	ITEM	SPECIFICATION	RMK																												
4.	BUBBLES AND STONES	<table border="1"> <thead> <tr> <th data-bbox="384 300 608 360">SIZE OF DEFECTS</th> <th colspan="2" data-bbox="608 300 1059 360">PERMISSIBLES NUMBER</th> <th data-bbox="1059 300 1353 360">MIN. DISTANCE BETWEEN DEFECTS (mm)</th> </tr> <tr> <td></td> <th data-bbox="608 360 831 421">ZONE A</th> <th data-bbox="831 360 1059 421">ZONE B</th> <td></td> </tr> </thead> <tbody> <tr> <td data-bbox="384 421 608 481">OVER 0.91</td> <td data-bbox="608 421 831 481">0</td> <td data-bbox="831 421 1059 481">0</td> <td data-bbox="1059 421 1353 481">--</td> </tr> <tr> <td data-bbox="384 481 608 542">0.76 0.90</td> <td data-bbox="608 481 831 542">0</td> <td data-bbox="831 481 1059 542">2</td> <td data-bbox="1059 481 1353 542">57</td> </tr> <tr> <td data-bbox="384 542 608 602">0.51 0.75</td> <td data-bbox="608 542 831 602">1</td> <td data-bbox="831 542 1059 602">3</td> <td data-bbox="1059 542 1353 602">57</td> </tr> <tr> <td data-bbox="384 602 608 663">0.25 0.5</td> <td data-bbox="608 602 831 663">3</td> <td data-bbox="831 602 1059 663">6</td> <td data-bbox="1059 602 1353 663">57</td> </tr> <tr> <td data-bbox="384 663 608 723">0.24 OR UNDER</td> <td data-bbox="608 663 831 723">--</td> <td data-bbox="831 663 1059 723">--</td> <td data-bbox="1059 663 1353 723">--</td> </tr> </tbody> </table>	SIZE OF DEFECTS	PERMISSIBLES NUMBER		MIN. DISTANCE BETWEEN DEFECTS (mm)		ZONE A	ZONE B		OVER 0.91	0	0	--	0.76 0.90	0	2	57	0.51 0.75	1	3	57	0.25 0.5	3	6	57	0.24 OR UNDER	--	--	--	
SIZE OF DEFECTS	PERMISSIBLES NUMBER		MIN. DISTANCE BETWEEN DEFECTS (mm)																												
	ZONE A	ZONE B																													
OVER 0.91	0	0	--																												
0.76 0.90	0	2	57																												
0.51 0.75	1	3	57																												
0.25 0.5	3	6	57																												
0.24 OR UNDER	--	--	--																												
5.	SCRATCHES	<table border="1"> <thead> <tr> <th data-bbox="384 748 667 808">SIZE OF DEFECTS (mm)</th> <th data-bbox="667 748 1353 808">ZONE A + ZONE B</th> </tr> </thead> <tbody> <tr> <td data-bbox="384 808 667 869">0.14 0.20</td> <td data-bbox="667 808 1353 869">TOTAL LENGTH 19 mm MAX.</td> </tr> <tr> <td data-bbox="384 869 667 929">0.06 0.13</td> <td data-bbox="667 869 1353 929">TOTAL LENGTH 50 mm MAX.</td> </tr> <tr> <td data-bbox="384 929 667 990">0.05 OR UNDER</td> <td data-bbox="667 929 1353 990">NO LIMIT.</td> </tr> </tbody> </table>	SIZE OF DEFECTS (mm)	ZONE A + ZONE B	0.14 0.20	TOTAL LENGTH 19 mm MAX.	0.06 0.13	TOTAL LENGTH 50 mm MAX.	0.05 OR UNDER	NO LIMIT.																					
SIZE OF DEFECTS (mm)	ZONE A + ZONE B																														
0.14 0.20	TOTAL LENGTH 19 mm MAX.																														
0.06 0.13	TOTAL LENGTH 50 mm MAX.																														
0.05 OR UNDER	NO LIMIT.																														
6.	OTHER DEFECTS	OTHER DEFECTS NOT STATED ABOVE (SUCH AS CHIPS, CRACKS, BRUISES, SHAR MARKS, EMBEDDED STONES, STRAINS, CLOUDS AND POLISHED PATTERNS) ARE PERMITTED WHEN THEY ARE NOT VISIBLE FROM THE VIEWING DISTANCE. LIMITS SAMPLES MAY BE REFERRED IN CASE OF NECESSITY.																													

KORTEK CORP. (All Rights Reserved)

1 0 . O P E R A T I O N O F C I R C U I T

10.1 POWER CIRCUIT.

The switching mode power supply is adopted for universal power supply.

The chassis (secondary side) is isolated from the power source (primary side) by the transformer T101.

By the winding of the transformer T101 connected to the drain of IC106 and the other winding connected to the control circuit, the IC106 is submitted to feed back by sync trans T102.

When the voltage of power source or load current is varied, it is detected by T102 and the voltage is applied to PIN 3 of IC106.

When the voltage applied to PIN 3 is varied, the conducting time of IC106 is varied to compensate output voltage for the change, which makes output voltage of T101 stabilized.

10.2 DPMS CIRCUIT

10.2.1 SUSPEND MODE

If the H or V sync input is inactive, the output of IC501 pin14 becomes high, and the output voltage of IC103 will be down.

Therefore the deflection circuit and the video amp circuit can not operate.

At this suspend mode, the LED on the front of this unit indicates Blinking.

The power consumption at suspend mode is less than 15W.

10.3 Interface circuit

This is composed of IC501.

IC101 circuit detects frequency and polarity and controls the displayed image.

IC101 performs functions as follows.

- DPMS function
- VIDEO MODE selection
- G/D correction control
- OSD control
- IMAGE SIZE, POSITION CONTROL
- IMAGE DATA MEMORY.

10.4 VIDEO DRIVE CIRCUIT.

The R, G and B input signals with analog level are applied to the pre-amplifier KA2506.

This section amplifies the output signal of a generator enough to drive a video output circuit and video of OSD buffering.

Video gain is controlled by the DC voltage of PIN 12.

Clamping pulse is applied to PIN 18 of IC201.(BACK PORCH CLAMP)

10.5 VIDEO OUTPUT CIRCUIT.

The pre-amplified R, G and B video signals are applied to the amplifier IC803(LM2405)

And then, these video signals are driven to the cathodes of CRT.

The CRT bias for accurate white balance is obtained by R, G and B bias controls circuit.

That circuit composed IC803.

10.6 DEFLECTION CIRCUIT.

This circuit has two ICs. IC301(TDA9113) is a monolithic IC for horizontal and vertical sync. processing. And IC201 is a monolithic IC for vertical power amplifier.

10.6.1 Vertical Deflection Circuit.

The vertical sync signal is applied to PIN 13,23 of IC301.

The vertical frequency of the oscillator can be varied by the RC constant at PIN 6,8.

Vertical screen size can be controlled by the current at PIN 13 of IC301.

IC201 is the vertical power amplifier that drives vertical DY.

10.6.2 Horizontal Deflection Circuit.

The horizontal sync signal is applied to PIN 1 of IC301.

The IC301 has the autsync detection function of frequency-locked loop that can look the H-oscillator over a wide frequency range.

Trapezium (by DC voltage applied at pin11)

Side-pin (by DC voltage applied at pin11)

H-size (by DC voltage applied at pin11)

11 . P C B I N F O R M A T I O N

- 11.1 MAIN PCB : MJ19FS3D82
- 11.2 SOCKET PCB : SM1982F1D0

12 . R E L I A B I L I T Y T E S T S P E C .

12.1 Environmental Test

The monitor unit must not be degraded and damaged by operating over the specified range and will meet specifications when returned to the operating environment.

KORTEK will perform these tests on the monitor prior to its release.

The monitor is required to pass these tests before mass production.

These tests are detailed in KORTEK environment specification.

12.2 Temperature test

- * Operating : 0 To 45
- * Storage : -20 To +60

12.3 Humidity test

- * Operating : 15% To 80% (Non condensing)
- * Storage : Maximum 90%

12.4 Drop test : Refer to KORTEK's ENVIRONMENTAL TESTS MANUAL.

12.5 Leakage current test : Refer to KORTEK's ENVIRONMENTAL TESTS MANUAL.

12.6 ESD test : Refer to KORTEK's ENVIRONMENTAL TESTS MANUAL.

12.7 Long life test.(MTBF)

The monitor shall have 50,000hrs MTBF when operated under any combination of conditions as detailed specification.

12.8. Altitude.

- * Operating : 0 ~10,000 ft
- * Non operating : 0 ~15,000 ft

KORTEK CORP. (All Rights Reserved)

13 . P I C T U R E S .

13-1. PCB ASS'Y

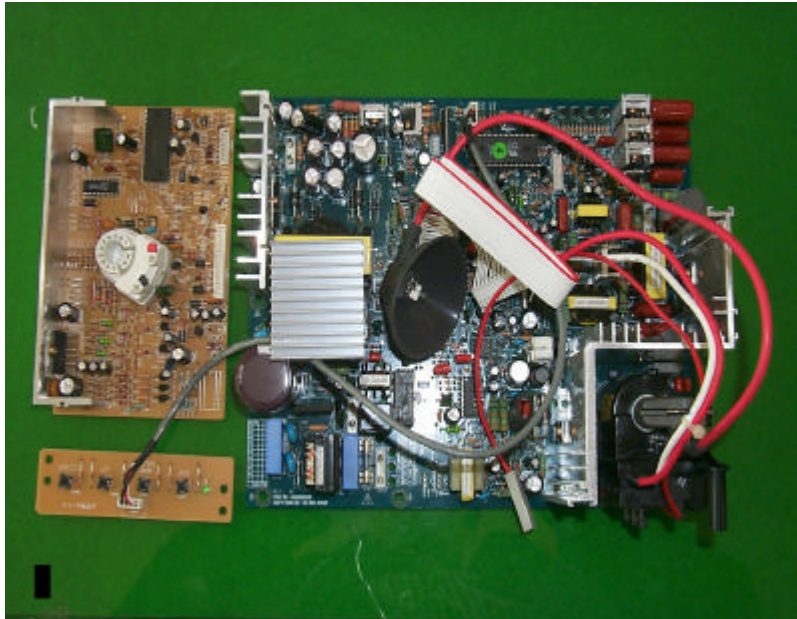

13-2. PCB & GUIDE CHASSIS ASS'Y

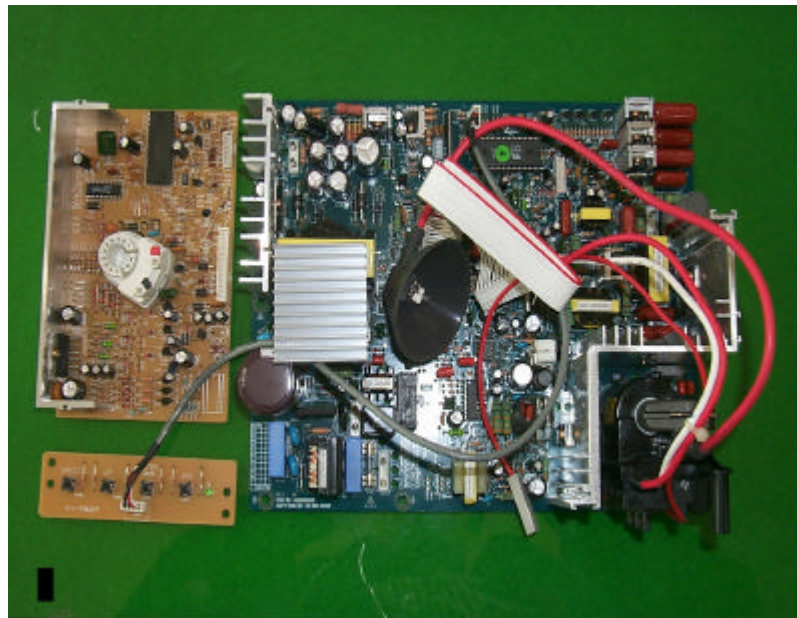

13-3. FRONT (STANDARD FRAME)



13-4. REAR (STANDARD FRAME)



KORTEK CORP. (All Rights Reserved)

DOCUMENT NO : 1982 *****-MS

REV. NO : 1

Page 26 Of 26