

# TOVIS

## An Introduction to Digital Monitors

### Part 2 - The Power Supply

Let's begin our detailed look at the Tovis digital monitor with the power supply. In fact, let's go back to the very beginning, at the AC (mains) input of the monitor. Right away, we see a notable difference between this monitor and the others we are used to repairing. Rather than connecting to an AC input connector on the deflection PCB, the AC input is connected to a separate "EMI Module." This is a small PCB upon which is mounted the components that we typically associate with the suppression of electromagnetic interference: AC input capacitors (C101, C102, C103, and C112) and the line filter itself. The engineers at Tovis have really taken this EMI suppression seriously, as there are two stages of EMI line filters (LF101 and LF102) in series. Nothing's going to get out of this monitor's SMPS and on to the AC power line, that's for sure. These components are typically low-to-zero failure devices.

Also included on the EMI Module is the degaussing circuitry. Unlike older, passive ADG (automatic degaussing) circuits, this one actually has a bit of active circuitry added that allows the ADG to operate under CPU control. It's a simple relay circuit that uses a transistor (Q102) as a "ground switch" to energize a relay coil. The base of the transistor is driven by the "degauss" output of IC801. What could be simpler?

Although we can now use an active control to turn the degaussing coil on and off, we still require a PTC thermistor (PTC101) in series with the degaussing coil. The degaussing coil's magnetic field can come on like a lion but it must leave like a lamb. That is to say, we cannot simply turn the coil off. The rapidly collapsing magnetic field would have just

the opposite effect that we require, magnetizing the shadow mask of the CRT instead of demagnetizing it.

The positive temperature coefficient thermistor has a low resistance when it's cold but a high resistance when it's hot. As soon as the degaussing coil is energized, current flows through both the PTC and the degaussing coil which, as you can see, are in series each other. Of course, when current flows through a resistor, it generates heat and as the PTC heats, its resistance increases, slowly choking off the current to the degaussing coil. After a predetermined length of time to allow the PTC to reach its maximum resistance (but with no actual sensing involved) IC801 says "enough already" and removes the base voltage from transistor Q102, de-energizing the relay and removing power from the degaussing coil.

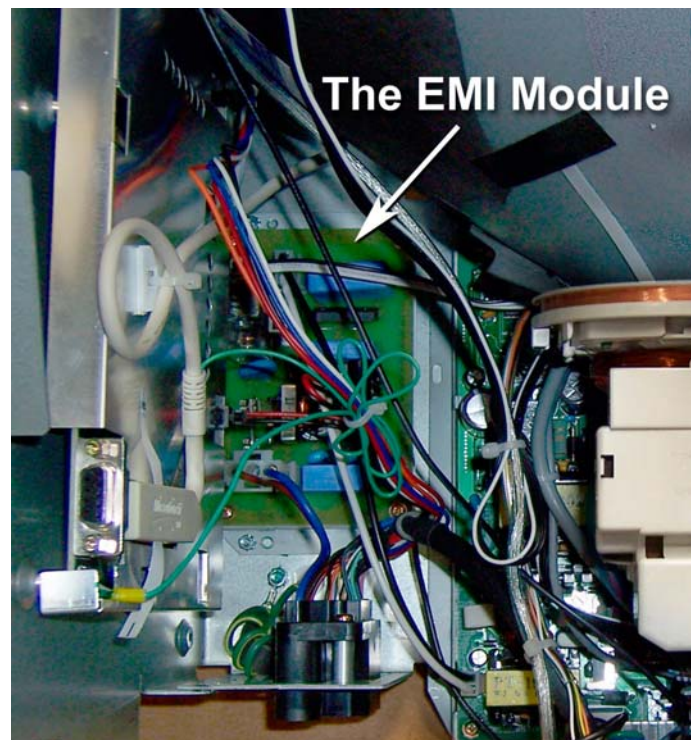

As with all such circuits, the degaussing coil will not operate again until the PTC thermistor cools off. However, unlike older designs, the PTC in this type of monitor does not require a “self-heating” element that keeps the PTC hot during monitor operation. Once the monitor has been degaussed (either automatically at start-up or manually) and the relay has dropped out, the PTC begins to cool and will be ready to go again in just a few minutes. A side benefit to this is that we save a watt or two of power as well. Energy saving is important in a monitor. There’s no sense wasting power if we can find a somewhat “hi-tech” way to reduce the overall power consumption. You’ll see in just a moment how the Tovis monitor carries this energy consciousness one step further.

Also included on the EMI module is the bridge rectifier (BD101) with an NTC thermistor (TH101) in its return

path. The NTC thermistor is, of course, for inrush current protection as featured in the December 2004 issue of Slot Tech Magazine (page 33 - What a Rush!). Following the bridge rectifier, a .68 microfarad capacitor that is yet another link in the chain of EMI suppression.

This EMI Module is starting to look a bit like a power supply but let’s leave the EMI module now and make our way to the main deflection PCB of the monitor, where we see a very interesting new development in monitor SMPS design.

Think for just a moment about every power supply you have seen in your life as a technician. Whether we’re talking about linear power supplies or switched-mode power supplies, what component almost always follows immediately after the bridge rectifier? It’s the filter capacitor, of course. Look at a thousand different

designs and you’ll see it again and again: AC input connects to diode(s) followed by a filter capacitor.

However, in this design, the positive output of the bridge rectifier (at W105) is not connected directly to the positive terminal of the primary filter capacitor (C104). There are two paths that the output of the bridge rectifier can follow.

One path passes through diode D154 and then to C104. But why do we need the diode? It’s already DC, isn’t it? Sure it is. It’s the output of a bridge rectifier and bridge rectifiers turn AC into DC. Is the current being “double-rectified” or something? Seems mysterious, doesn’t it?

The answer lies down the other path so let’s go back to the positive output of the bridge rectifier (at W105) and follow it straight across to what appears to be the pri-

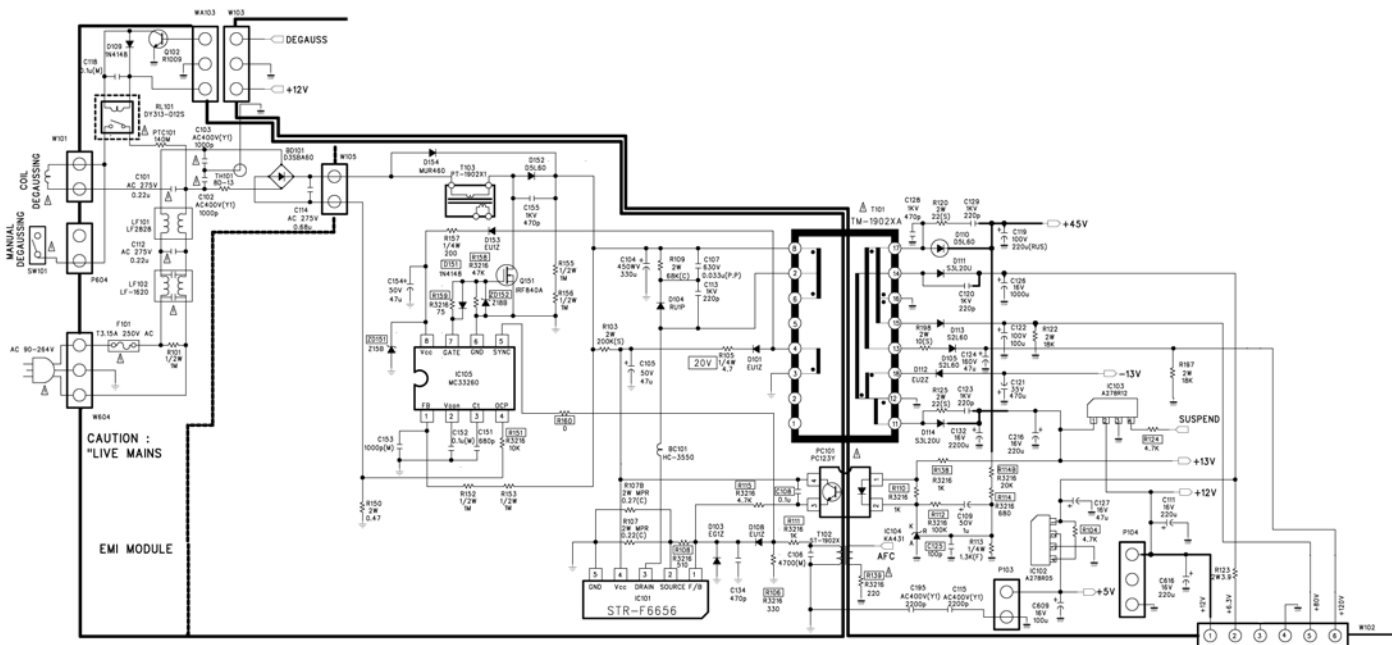

mary winding of a transformer (T103) that is turned sideways, with nothing at all connected to the secondary winding. From the right side of this transformer winding, we can follow the current path through diode D152 and then to the positive lead of our friend the filter capacitor. What is going on here? Why are there two paths and why do we have the “extra” diodes?

### Harmonic Currents and Active Power Factor Correction

If you’re a regular reader of Slot Tech Magazine, you know all about harmonics and switched-mode power supplies. You know about the power-sapping third harmonic and how it robs your casino of power. If you need a refresher, the topic was covered extensively in the August 2004 issue.

Harmonic currents are a direct result of the way in which a switched-mode power supply (SMPS) draws current from the system. The input circuit of an SMPS is a bridge rectifier that changes the 120 volt AC input to DC. A capacitor smoothes this DC to eliminate voltage ripples and the resultant DC bus has a voltage of about 170 volts when the AC rms input is 120 volts. Although the AC voltage is a sine wave, the rectifier draws its current in spikes as shown in Figure 3. These spikes require that the AC supply system provide harmonic currents, primarily 3rd, 5th and 7th. These harmonic currents do not provide power to the SMPS, but they do take up distribution system capacity. The principal harmonic current is the 3rd (180 Hz) and the amplitude of this current can be equal to or even greater than that of the fundamental current.

The power supply used in the Tavis monitor is really two power supplies in one. At a glance, even a novice technician will recognize a standard SMPS design in power transformer T101 and its associated PWM controller/MOSFET, this time as a single module, IC101, an STR-F6656. The unregulated, filtered DC enters pin 8 on the primary winding of the transformer. The other end of the

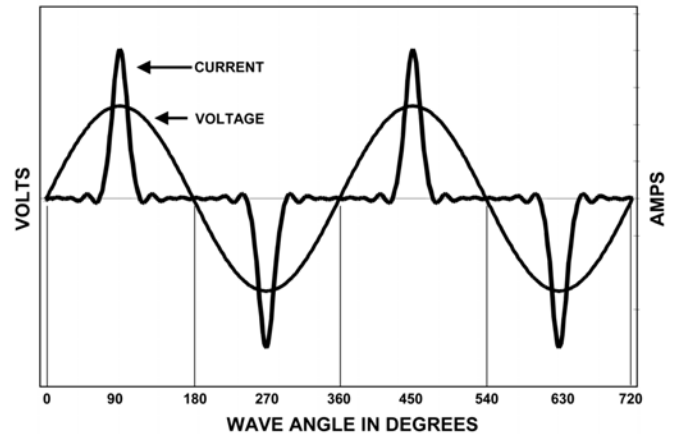

Figure 3. - Although the AC voltage is a sine wave, the rectifier draws its current in spikes

primary (pin 2) is connected to the drain of the MOSFET that’s inside the STR-F6656.

The source, as usual, is connected through a fraction of an ohm resistor (.22 ohm is typical) to ground. This is our over-current protection (OCP) detector. If too much current passes through this resistor (due to a shorted load, for example) it develops a substantial voltage due to IR drop. When IC101 see this voltage between its source and ground, it

## ASSA® Desmo

### REDUCE YOUR EXPOSURE FROM DAYS TO MERE SECONDS!

The ASSA® Desmo RC, a Quick Change Removable Core Lock, offers the Maximum Security Solution you have been searching for:

- Controlled Management Key allows lock to be changed in seconds
- Provides continuous protection against vulnerability of lost & stolen keys
- Dramatically reduced replacement time provides for significant ROI

The ASSA® Desmo RC lock features include:

- Patented Key Control
- Maximum Control of Key Duplication
- Extremely Durable Key & Lock

**ABLOY SECURITY, INC.**  
 800-367-4598 • www.abloyusa.com

An ASSA ABLOY Group company

SECURITY SOLUTIONS

says to itself “Holy Mackerel! There’s a short somewhere!” and it turns itself off by removing the voltage from the gate of its internal MOSFET. About once a second, the STR-F6656 will try turning itself on, see the voltage and turn itself back off. That is what creates the ticking sound that you hear in a monitor with a shorted horizontal output transistor. It’s the OCP in action.

The second power supply is really the first power supply! Look at the circuit made from MOSFET Q151 and its associated controller, IC105. It kind of looks like it is its own SMPS, doesn’t it? However, the drain of the MOSFET is connected to the sideways transformer thingy, T103. What’s this all about?

This, my friends, is a tricky little circuit called a “boost” power supply. In this case, it’s more specifically called a “follower boost.” The sideways transformer is, electrically speaking, just a coil. We’re simply not using the secondary winding for anything. What we ARE using is the coil’s ability to store energy, not as a charge (as we do with a capacitor) but in the form of a magnetic field.

Our goal here is to change the way the monitor’s filter capacitor draws current from the bridge rectifier and, subsequently, the AC (mains). We’re looking for a way to boost the pulsating DC output of the bridge rectifier so that instead of charging the

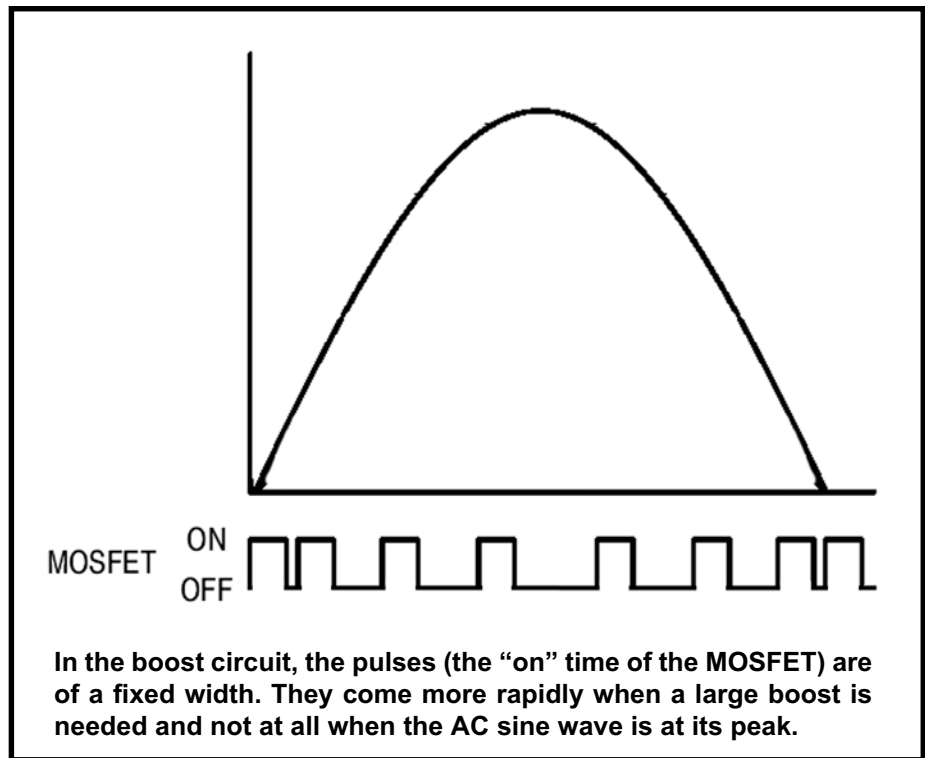

filter capacitor with narrow, harmonic-producing spikes of current, we have a steady flow of current flowing from the bridge rectifier into the filter capacitor.

We accomplish this feat by pulsing MOSFET Q151. When

Q151 is turned on, current will flow from the positive output of the bridge rectifier, through the coil in T103 and through Q151 to ground. The coil is our load and it builds up a nice big magnetic field. When Q151 is turned off, the magnetic field collapses. This

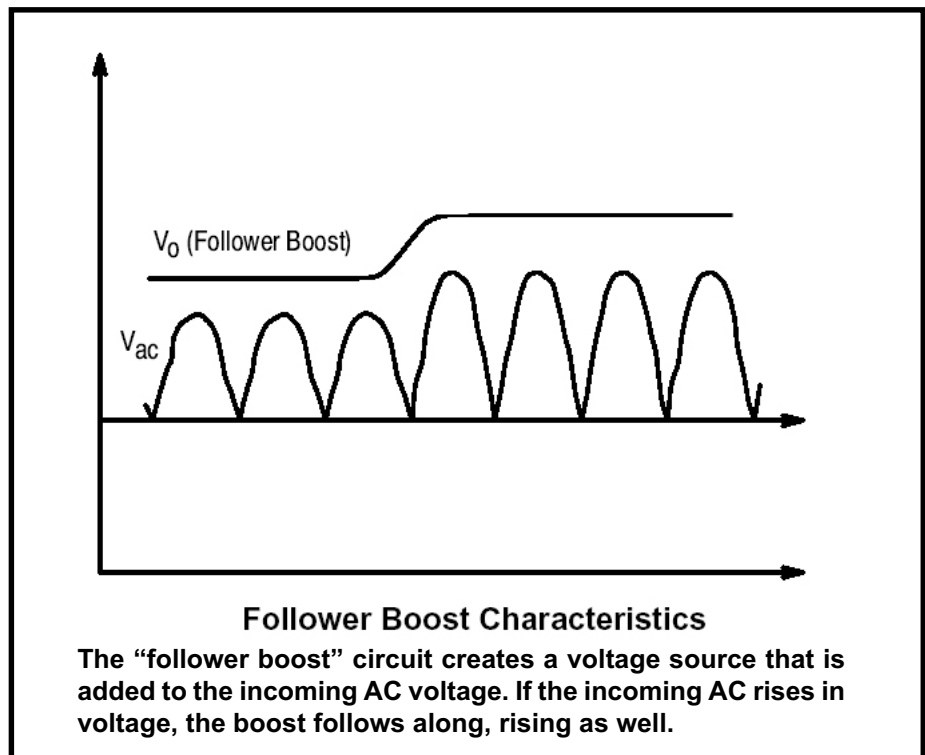

rapidly collapsing magnetic field slices across the coils of copper wire and turns the coil into an electric generator in a process called “induction.” This newly generated voltage (you can kind of think of the coil as a battery for this moment in time) is now IN SERIES with the output of the bridge rectifier and, just like two or more dry cell batteries in series in a flashlight, the voltages are added together.

It’s called a “follower boost” circuit because this newly generated voltage is added to the incoming voltage. If the incoming AC rises, the boost follows along, rising as well. We don’t care about regulating the voltage at this point because we’re going to do that next with the PWM part of the SMPS.

There is a notable difference between the way this circuit operates and the way the PWM controller works. PWM is just what it says; it is pulse-width modulation. The operating frequency remains constant while the duty-cycle of the pulse is shortened or lengthened in order to maintain a regulated output voltage.

In the boost circuit, the pulses (the “on” time of the MOSFET) are of a fixed width but they come more rapidly when a large boost is needed and not at all when the AC sine wave is at its peak.

The result is that we are taking a sine wave in and pro-

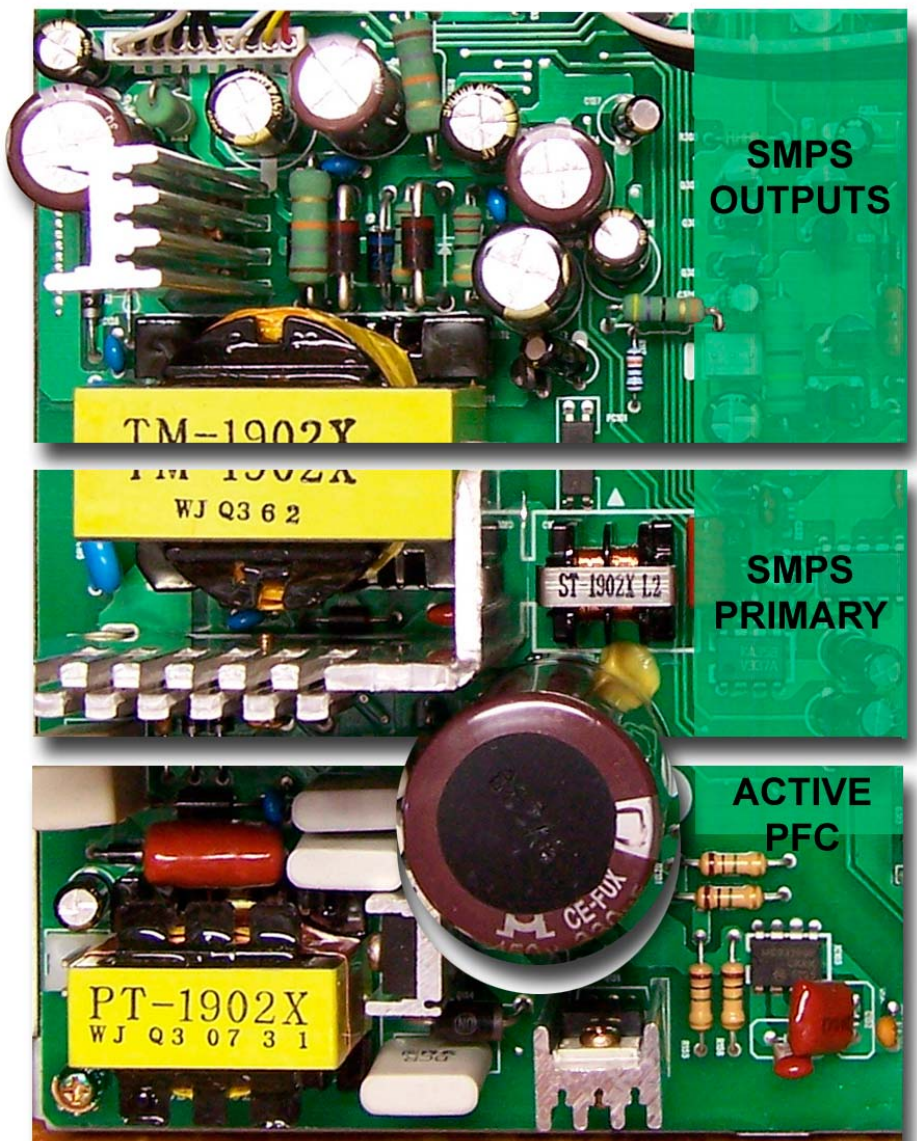

The power supply can be divided into three sections: The active power factor correction, the SMPS primary and the SMPS outputs.

ducing a constant voltage out and the upshot of this whole thing is that instead of charging the filter capacitor only during the brief peak period of the AC sine wave, we can keep a constant charge on it and substantially reduce (or eliminate altogether) the third-harmonic content of the system. This is known as “active power factor correction” or PFC.

The diodes we were talking about at the beginning of this discussion (D152 and D154)

are a sort of electronic “anti-siphon” valve. They are used to ensure that the current doesn’t “backflow” when, for example, the output voltage of the boost follower circuit is higher than the output voltage of the bridge rectifier.

### Other Things of Interest

Notice that IC105 gets its power (Vcc) from the 20 volt secondary of power transformer T101. The voltage is picked off at pin 4 of the transformer, rectified by di-

# MC33260

## GreenLine™ Compact Power Factor Controller: Innovative Circuit for Cost Effective Solutions

The MC33260 is a controller for Power Factor Correction preconverters meeting international standard requirements in electronic ballast and off-line power conversion applications. Designed to drive a free frequency discontinuous mode, it can also be synchronized and in any case, it features very effective protections that ensure a safe and reliable operation.

This circuit is also optimized to offer extremely compact and cost effective PFC solutions. While it requires a minimum number of external components, the MC33260 can control the follower boost operation that is an innovative mode allowing a drastic size reduction of both the inductor and the power switch. Ultimately, the solution system cost is significantly lowered.

Also able to function in a traditional way (constant output voltage regulation level), any intermediary solutions can be easily implemented. This flexibility makes it ideal to optimally cope with a wide range of applications.

### General Features

- Standard Constant Output Voltage or “Follower Boost” Mode
- Switch Mode Operation: Voltage Mode
- Latching PWM for Cycle-by-Cycle On-Time Control
- Constant On-Time Operation That Saves the Use of an Extra Multiplier
- Totem Pole Output Gate Drive
- Undervoltage Lockout with Hysteresis
- Low Start-Up and Operating Current
- Improved Regulation Block Dynamic Behavior
- Synchronization Capability
- Internally Trimmed Reference Current Source
- Pb-Free Package May be Available. The G-Suffix Denotes a Pb-Free Lead Finish

### Safety Features

- Overvoltage Protection: Output Overvoltage Detection
- Undervoltage Protection: Protection Against Open Loop
- Effective Zero Current Detection
- Accurate and Adjustable Maximum On-Time Limitation
- Overcurrent Protection
- ESD Protection on Each Pin

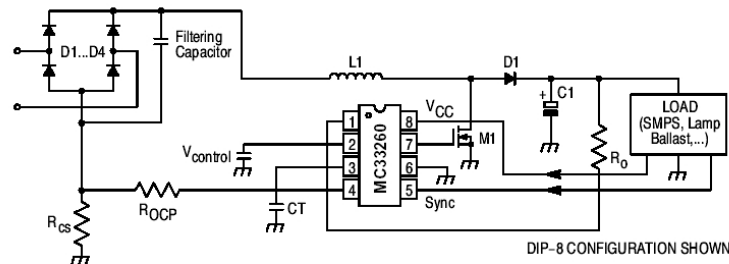

Figure 1. Typical Application



ON Semiconductor®

<http://onsemi.com>

### MARKING DIAGRAMS

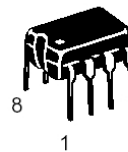

DIP-8  
P SUFFIX  
CASE 626

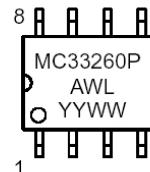

SO-8  
D SUFFIX  
CASE 751

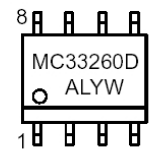

A = Assembly Location  
WL, L = Wafer Lot  
YY, Y = Year  
WW, W = Work Week

### PIN CONNECTIONS

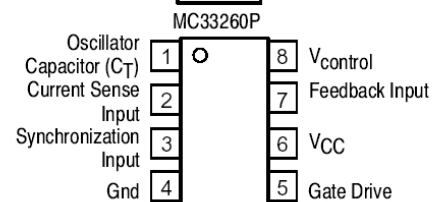
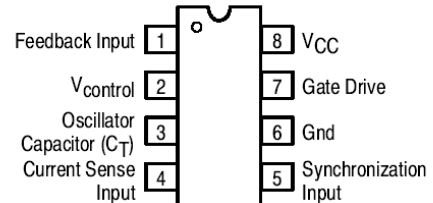

### ORDERING INFORMATION

Device	Package	Shipping†
MC33260P	Plastic DIP-8	50 Units/Rail
MC33260D	SO-8	98 Units/Rail
MC33260DR2	SO-8	2500 Tape & Reel
MC33260DR2G	SO-8 (Pb-Free)	2500 Tape & Reel

†For information on tape and reel specifications, including part orientation and tape sizes, please refer to our Tape and Reel Packaging Specifications Brochure, BRD8011/D.

ode D153 and filtered by electrolytic capacitor C154. This means that the follower boost circuit actually doesn't begin operating until the main SMPS is already up and running. We can see how the STR-F6656 gets its "kick start" from the raw DC, through resistor R103 and thereafter runs from the same 20 volt transformer secondary, this time rectified by diode D101 and filtered by capacitor C105.

I suppose my point here is that, if the PFC circuit were not operating at all, you likely wouldn't know it, as the unit would simply carry on as a regular SMPS. A much more likely failure scenario is that Q151 would short-circuit. This would blow the fuse. If the MOSFET inside the STR-F6656 blows, this would also blow the fuse. In either case, pay close attention to resistor R150, .47 ohm, 2 watts. It's in the negative return path of the bridge rectifier. If any sort of high-current weirdness happens on the primary side of the power supply, R150 might open-circuit. Likely electrolytic capacitor failures to look out for are probably C105 and C154. I am not saying that these capacitors (or anything else, for that matter) WILL fail. I am just saying that, in my experience with all types of monitors, these will be the likely weak points. I understand from my source within the company that Tovis has used especially high quality, low-esr, capacitors in these critical applications.

## KA278R12 Low Dropout Voltage Regulator

### Features

- 2A / 12V Output low dropout voltage regulator
- TO220 Full-Mold package (4PIN)
- Overcurrent protection, Thermal shutdown
- Overvoltage protection, Short-Circuit protection
- With output disable function

### Description

The KA278R12 is a low-dropout voltage regulator suitable for various electronic equipments. It provide constant voltage power source with TO-220F-4 lead full mold package. Dropout voltage of KA278R12 is below 0.5V in full rated current(2A). This regulator has various function such as peak current protection, thermal shut down, overvoltage protection and output disable function.

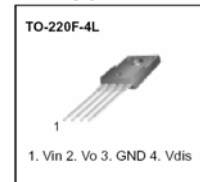

### Internal Block Diagram

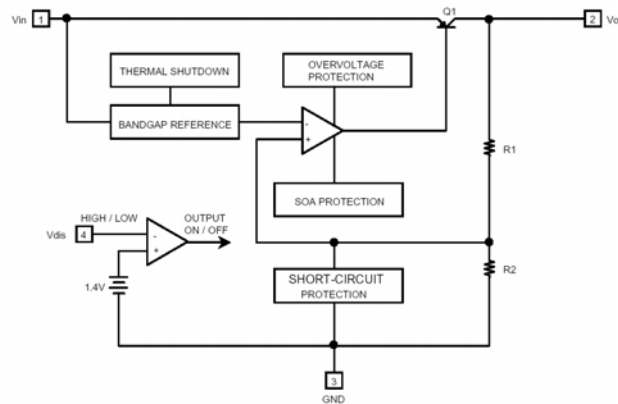

Rev. 1.0.2

©2001 Fairchild Semiconductor Corporation

The output side of the power supply is all completely standard with the exception of the A278R12 voltage regulator. This is a nifty little voltage regulator, used for the +12 VDC output. It's not so much that we really needed another regulator here - after all, the SMPS itself can provide us with a nice, regulated +12 VDC output. The A278R12 is cool because it has a "disable" input and can be turned on or off with an external signal from the monitor's processor. In this case, the sig-

nal is called "suspend." If the "suspend" signal is high, the regulator is turned on. If the "suspend" signal is low, the +12 VDC output is turned off. Since the +12 VDC is used to power things like the IC that controls the high voltage (we'll look at this in detail in a subsequent issue) killing the +12 VDC output is a handy way to handle things like EHT shutdown.

- Slot Tech Magazine